

# ISOKERN DM BRICK CLAD INSTALLATION GUIDE (STOVE INSIDE RECESS)

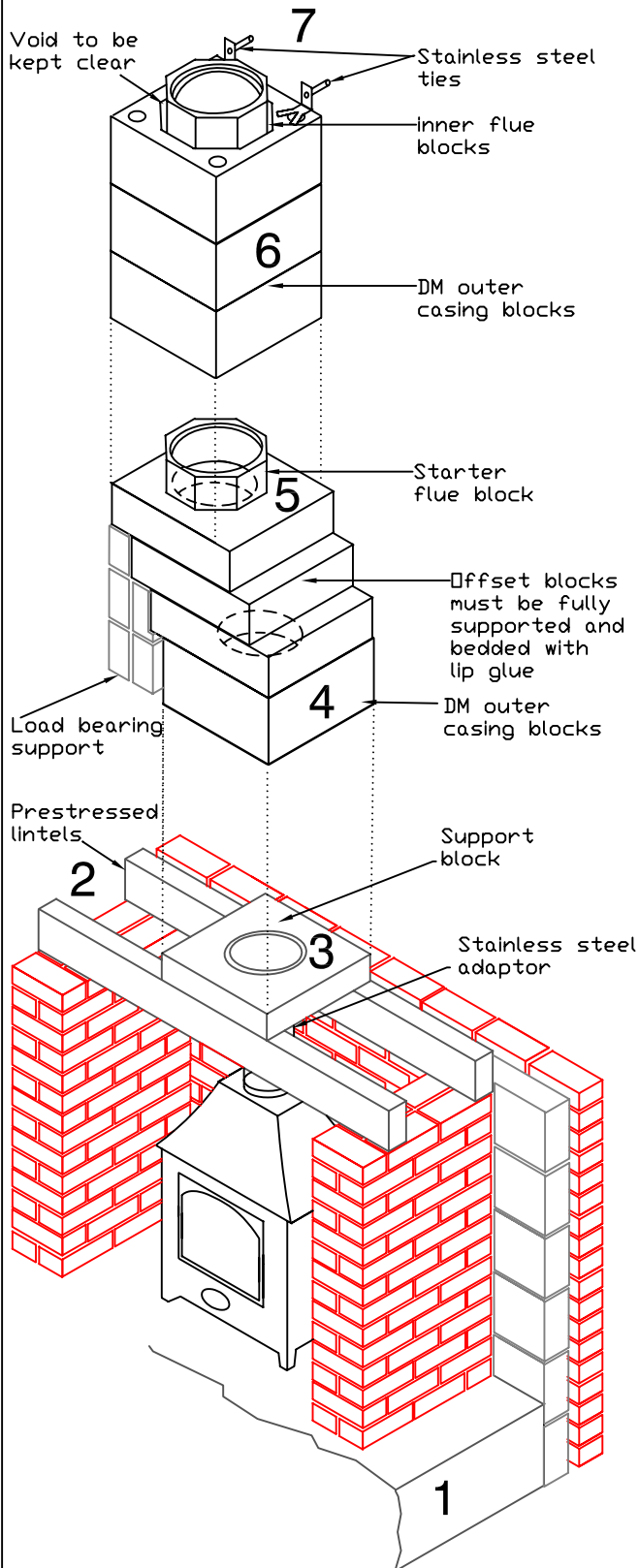

1) Construction begins by providing a suitable foundation/constructional hearth in accordance with Building Regulations and site requirements.

2) Prestressed lintels or a suitable cast-in-situ concrete slab lintel must be provided above the stove recess, please make sure they are strong enough to carry the load. (See appropriate Isokern DM6 drawing for hole size). It is recommended to have a minimum of 600mm of stove flue pipe before connecting to the support block.

3) The support block is bedded onto the lintels using lip glue. A stainless steel adaptor is used to create a positive connection from the support block to the stove flue pipe.

4) Bed the first outer casing onto the support block using lip glue making sure the rebate (raised lip) is uppermost. The starter flue block is then put inside the casing bedded with lip glue. The socket on the starter flue block must be uppermost and the air gap between the starter flue and the casing should be kept clear. Lip glue joints should be approximately 2mm thick, a special bag is provided for ease of application.

5) Offset blocks 'if required' must be glued together with lip glue and be fully supported. Please note a chimney should be built straight where ever possible. A starter flue block will be required above the offset blocks to stagger the joints between the outer casing and inner flue blocks.

6) Casings and flue blocks are added using lip glue for all joints. Ensure the air gap between the inner flue and outer casing remains clear. The outer surface of the casings to be finished with plasterboard on dabs or plaster. The side that faces the wall does not need an external finish.

7) External chimneys must be tied to the structure at maximum intervals of 1.5m and at the point where it departs from the roof using 2 x suitable stainless steel wall ties. These are fitted into the casing joints and are not always required for internal chimneys. Please consult the Isokern technical office.

# ISOKERN DM BRICK CLAD INSTALLATION GUIDE (STOVE INSIDE RECESS)

**SCHIEDEL**

ISOKERN®

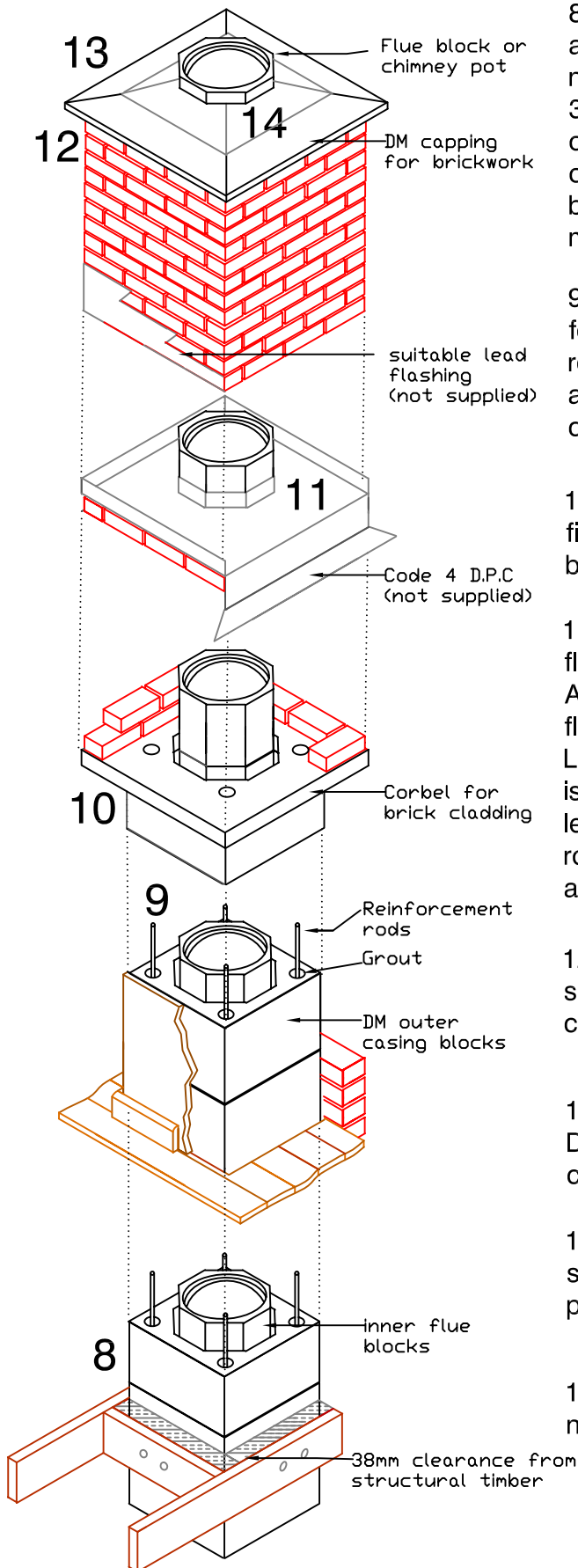

8) Where the chimney passes through a floor or roof, a sliding joint is made using mineral wool or similar non-combustible material. 38mm clearance must be maintained between the outer face of the chimney and any structural timber or loose combustible material. Floor boards, skirting boards, dado rails and other non-structural components may, however, be in contact with the chimney.

9) High tensile steel reinforcement rods will be required for all chimneys with a height that exceeds 1.4m above the roof line, 1.1m if the wind speed exceeds 44ms. These rods are available from Isokern and must be grouted (1:3 cement/sand) into the holes provided in the outer casings.

10) To take the brick or stonework externally a corbel is fitted just below the roof. Use trusses and trimmers to brace the cladding as it passes through the roof.

11) Code 4 lead tray with 50mm upstands and stepped flashing to be fitted in accordance with Building Regulations. A 50mm upstand should be fitted tight to the outside of the flue block and where possible turned in by approx 10mm. Lead trays should be coated with bituminous paint where it is in contact with mortar. The D.P.C tray should be fitted at least 150mm above the lowest point of intersection with the roof. Weepholes should be provided at the front of the stack above the tray for water drainage.

12) An optional DPC can be fitted below the capping, it should be dressed up the outside of the last flue block or chimney pot.

13) Isokern concrete capping to be lip glued onto the DPC/brickwork. If the DPC is lead then it should be coated with bituminous paint.

14) Flaunching with 1:3 cement and sharp sand to seal around the flue block or chimney pot. A chimney pot should be bedded at least 75mm into the brickwork.

15) If you have any queries or questions please do not hesitate to contact Schiedel Isokern.

Schiedel Isokern

14 Haviland Road, Ferndown Industrial Estate,  
Wimborne, Dorset, BH21 7RF

Tel: 01202 861650 Fax: 01202 861632

Web: [www.isokern.co.uk](http://www.isokern.co.uk)