

A BFCMA GUIDE

C1/Sfb

(56-11)

(A3)

October 2007

A GUIDE TO CHOOSING AND USING FLUES AND CHIMNEYS FOR DOMESTIC GAS BURNING APPLIANCES

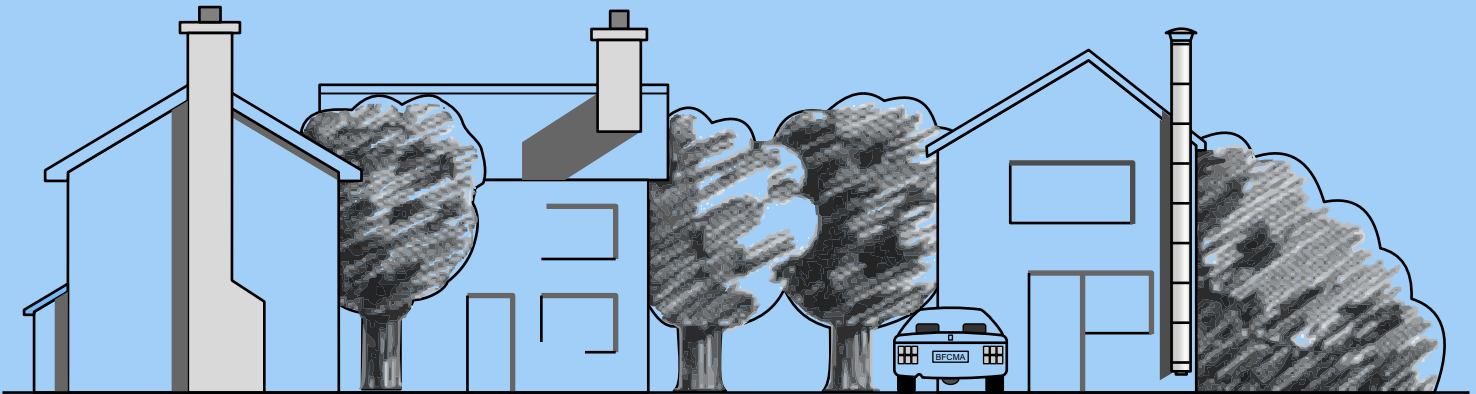

This document has been produced by the BFCMA to provide advice and general guide lines on choosing and maintaining chimneys and flues for maximum performance, safety and durability. It is important to ensure that the chosen chimney and heating arrangements as a whole are suitable for the purpose intended and conform to the relevant regulations and standards.

The BFCMA is Britain's only Trade Association representing manufacturers and sole UK distributors of factory made chimney and flue products. It was established to promote the advantages of chimneys and encourage continued improvements in standards, efficiency and service.

Practically all the products manufactured by members of the British Flue and Chimney Manufacturers Association are suitable for gas fired appliances. Some products are specifically produced for gas equipment only. This leaflet is designed to act as a guide and to indicate which products may be specified and incorporated according to the appliances being used.

All members of the BFCMA offer a free information service on request.

The BFCMA also publish a similar document providing relevant guidance and useful information relating to chimneys for solid fuel appliances.

Published by the:-

BRITISH FLUE AND CHIMNEY MANUFACTURERS ASSOCIATION
2 Waltham Court, Milley Lane, Hare Hatch, Berks, RG10 9TH
Tel: 0118 940 3416 Fax: 0118 940 6258
Email: info@feta.co.uk Website: <http://www.feta.co.uk>

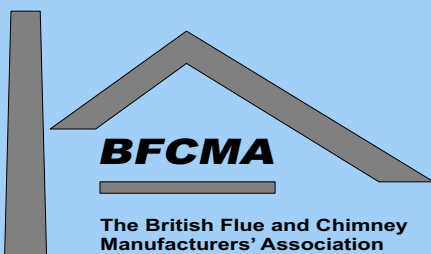

A GUIDE TO FLUES AND CHIMNEYS FOR GAS APPLIANCES

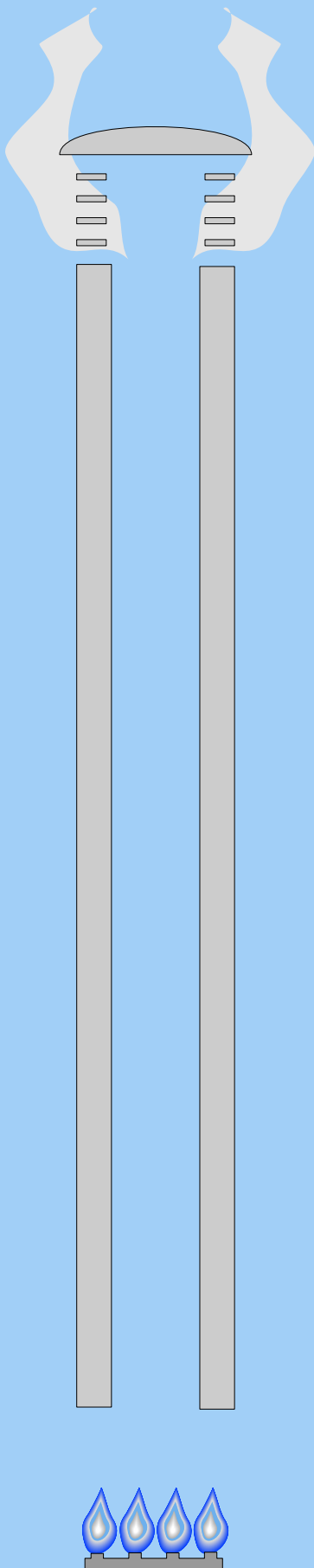

INTRODUCTION

The chimney is a practical asset for any house and an important part of the heating system. The products of combustion from a gas fired appliance have to be ducted safely from the heating appliance to the outside atmosphere. When operated normally, traditional gas appliance primary flue temperatures are in the range of 150° C - 250° C. These can be reduced to between 130° C -160° C where the appliance is fitted with a draught hood or diverter. If the appliance is not operating normally this temperature could increase to 300° C.

Connection of a gas appliance to a badly constructed or excessively cooled chimney can result in poor draught or condensation within the flue system. Condensation may occur if the temperature of the flue falls below 100° C.

The constructions and application of any chimney or flue serving gas fired equipment is covered by UK Building Regulations as well as European and British Standards and the Gas Safety (Installation and Use) Regulations. Whilst these differ in emphasis, they all demand the safe application of the chimney no matter where and how used. These Regulations and Standards dictate the minimum criteria which it is necessary to apply if the chimney / flue is to function safely and correctly. The appropriate Regulations and Standards are listed later in this document on page 9.

Users of this guide are reminded that it is a legal requirement to use a competent person, such as a CORGI registered installer for any work involving the installation of a gas appliance.

When installing a gas appliance and chimney, it is vital to check beforehand that the proposed flue size conforms to the appliance manufacturers instructions. In many common cases a flue size of 200 mm diameter or 185 mm square can be used with the advantage of being suitable for other fuel burning appliances. This keeps heating options open for future change or up-rating of appliances. If the chimney has a flue size too large for the appliance manufacturers recommendations the flue can be reduced by using a suitable flue lining system. Chimneys serving gas appliances may be constructed using a number of techniques and a wide variety of materials.

Where an appliance is to be installed in an existing fireplace, the chimney must be thoroughly cleaned and inspected. Any damaged or decaying masonry must be made good in order to ensure the chimney is leak free and water proof. It is essential to ensure there is a full clear flue-way throughout the length of the chimney and that this cannot become blocked with loose masonry and/or deposits from previous fuels. Unless the chimney is already lined with a clay or refractory concrete liner which is proven by inspection to be in good condition the chimney should be lined with a flexible metal flue liner certified to BS EN 1856 and connected to either a gather unit, a closure plate above the fireplace or a Gas Flue Collector Box assessed and certified to BS715: 2005. **NOTE: Where back boilers are to be served by a masonry chimney, (new or existing), the flue should always be lined with a flexible stainless steel liner, normally of 125mm in diameter.** This is to ensure that the appliance is able to operate efficiently and also reduces the problems often associated with the formation of condensation

It is a mandatory requirement for all new chimney and flue configurations to be commissioned to ensure that they are able to safely evacuate products of combustion. That involves the use of a flue gas spillage test for the appliance and a smoke tests for the flue and chimney. Whilst the procedures are not defined in this document, appropriate requirements will be found in the Regulations and Standards referenced throughout this document.

Where the appliance is to be installed in a property that has no chimney or fireplace opening a chimney and substitute fireplace opening must be provided. The chimney can be formed with a metal double walled prefabricated flue system certified to BS EN 1856 Depending on the type of appliance an approved gas terminal may be required. The double walled prefabricated flue system must be installed in accordance with the manufacturers instructions ensuring that it incorporates all necessary fire stops and ceiling penetration components of the pattern used during the assessment and approval procedure. Double wall gas vent or flue systems to BS EN 1856 should be run internally wherever possible in order to limit condensation.

As an alternative, a chimney can be formed from a masonry construction incorporating clay liners certified to BS EN 1457 or concrete liners certified to BS EN 1857. Gas flue blocks certified to BS EN 1858 may be used to form a chimney for some gas fires. See paragraph c) on page 6 for more details.

TYPES OF APPLIANCE

GAS FIRES WITHOUT BACK BOILERS

Complying with BS 7977:Part 1 (formerly BS 5258: Part 5)

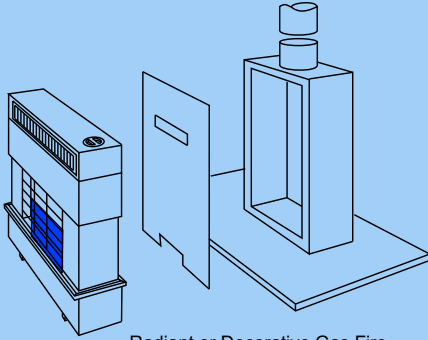

Radiant or Decorative Gas Fire without back boiler being applied to a metal flue gas collector box to BS 715: 2005. The closure panel is supplied as part of the gas fire.

For double wall metal flue systems a substitute fireplace recess is conveniently available in the form of a metal flue collector box which must conform to BS715: 2005. Alternatively, starter or recess units of concrete block systems complying with BS EN 1858 can be used. These may require a special attachment to the closure plate to prevent flue gas impingement directly onto the blocks. The gas fire installation instructions will give details of any special requirements.

The fireplace recess/builders opening formed will, under all normal circumstances, be surrounded by a false chimney breast. This may be constructed of masonry or fire resistant panelling. Alternatively factory made metal chimney breast systems are available.

GAS FIRES WITH BACK BOILERS

Complying with BS 7977:Part 2 (formerly BS 5258: Part 8)

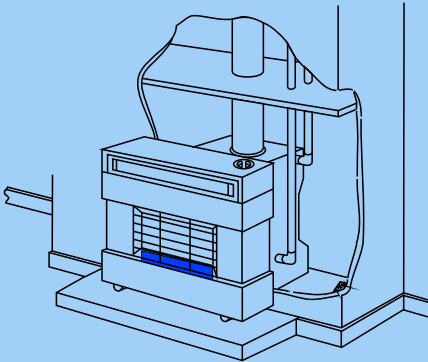

Radiant or Decorative Gas Fire with back boiler installed into a false chimney breast with a non-combustible horizontal closure panel which seals off the flue and the plumbing pipework to the back boiler location.

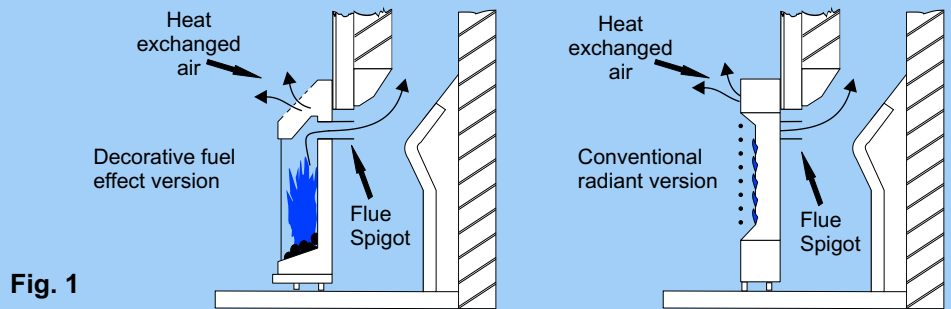

Fig. 1

With the availability of gas fires that simulate a solid fuel fire and other new designs of gas appliances, there is now a greater variety of appliances from which to choose. With such a large variety, it is essential that the appliance manufacturers instructions are adhered to because there may be special requirements to be met. The following sections outline the basic choices available.

These types of fires have a small flue spigot outlet and represent what has been for many years the traditional type of radiant gas fire. Some may be combined with a back boiler unit. These types of appliance are also available with a simulated solid fuel bed instead of radiant panels. Under such circumstances the fire front will usually be enclosed with glass and a typical arrangement is shown in Figure 1

The minimum size of flue for this category is normally 125mm diameter. The fire should be fitted to the front of a closure plate which is normally supplied with the heating appliance. The flue spigot will fit through the opening in the closure plate and discharge the flue gases into the existing fireplace recess, builders opening or into a flue collector box complying with BS715: 2005. Gas Flue block systems complying with BS EN 1858 may also be used. The installation of these appliances is covered by BS5871 part 1.

INSET LIVE FUEL EFFECT GAS FIRES

Complying with BS 7977:Part 1 (formerly BS 5258: Part 16)

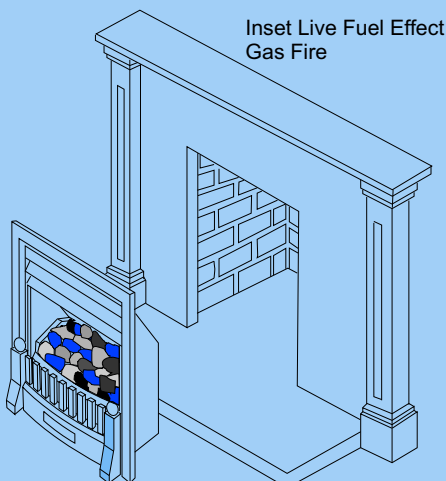

Designed to sit into a fireplace recess/builders opening or flue box, these types of appliance imitate a solid fuel fire and have a heat exchanger. The flue gases exit the combustion area via a flue spigot (see Figure 2)

... continued ...

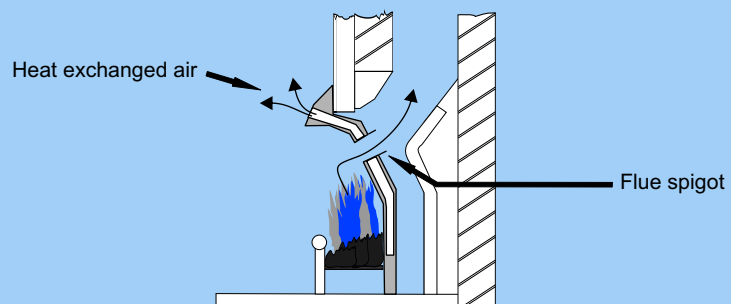
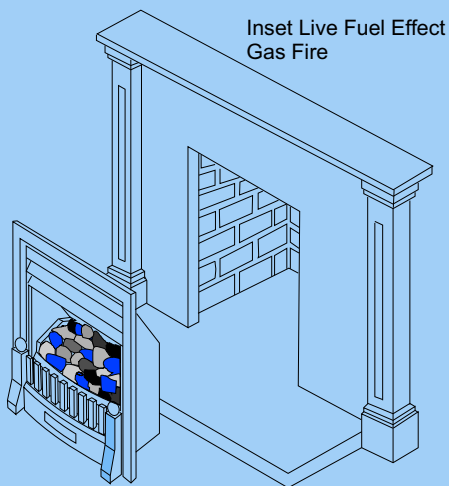

Fig. 2

**INSET LIVE FUEL EFFECT
GAS FIRES**
Complying with BS 7977:Part 1
(formerly BS 5258: Part 16)

(continued)



**DECORATIVE FUEL EFFECT GAS
APPLIANCES Complying with BS
5258: Part 12**

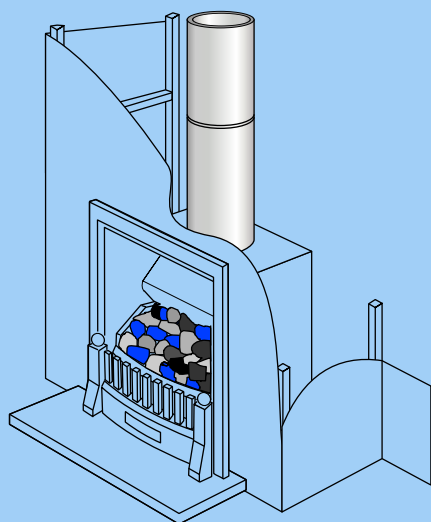

Decorative Fuel Effect Gas Fire installed within a metal flue gas collector box to BS 715: 2005.

The minimum flue size for this type of appliance is normally 175 mm diameter. However, there are now many appliances approved for use with a 125mm diameter flue which meets the requirements of BS EN 1856, or for use with gas flue blocks complying to BS EN 1858. It is especially important to have the full set of the appliance installation instructions available in order to ensure the correct flue size is selected. The advice on flueing detailed above in the introduction is applicable. However, the following additional points should be noted;

- 1) Where a 175mm flue is needed this may need to be constructed to a solid fuel flue and chimney specification. As such consideration should be given to the use of a 200 mm diameter chimney suitable for solid fuel. This will then provide for future changes of appliances.
- 2) Flue collector boxes for this type of appliance are available with a variety of flue connections to suit various applications. It is important to ensure the correct design of box is used with the correct appliance. The appliance manufacturers instructions should give appropriate advice. Alternatively, contact members of the BFCMA for guidance.

The installation of these appliances is covered by BS 5871: Part 2.

These types of appliances also imitate a solid fuel fire. They consist of a fire grate and artificial coals or logs with a gas burner. They are to be located into a builders opening, fireplace recess or flue box. There is no heat exchanger or flue gas spigot (see Figure 3).

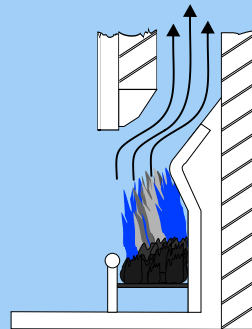

Fig. 3

Unless the manufacturer's approval certification indicates that the appliance has been approved for use with a specific chimney or flue system designed for gas fired appliances, this type of appliance must be served by chimneys suitable for solid-fuel appliances. Use of the incorrect type of chimney is dangerous. A thorough check should be made with the appliance manufacturer if the classification is uncertain.

The wide choice of chimneys available includes prefabricated insulated stainless steel chimneys with either stainless steel, refractory concrete or ceramic linings and complying with BS EN 1856 or BS EN 13063. Specially constructed metal flue boxes complying with BS 715: 2005 are also available for this type of fire.

Chimney block systems that can also be used with solid fuel appliances are suitable with this type of gas burning appliance. Unlined masonry chimneys should be lined when a new appliance is fitted to assist in the safe operation of the flue. Prefabricated concrete fireplace recesses are also available for use with most of these chimney systems and are capable of accepting a wide range of appliances. They also provide the option to change to other types of fuel burning appliances should it be necessary. A flue size of 200 mm diameter or 185 mm square is generally required for a standard 410 mm or 460 mm wide by 560 mm or 610 mm high opening. If a larger opening is required such as for an angle nook construction then the chimney size will have to be increased pro-rata. The appliance manufacturer should be consulted for further information. The installation of these appliances is covered by BS 5871 Part 3.

OPEN FLUED WATER HEATER

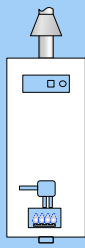

Open flued gas water heaters should be connected to a double wall gas vent system complying with BS EN 1856 and installed in accordance with BS 5440 such that it passes through the inside of the building. Alternatively, it can discharge into a block or traditionally constructed chimney.

It is illegal to install open flued gas fired appliances of any description in a bathroom, shower or garage. Only water heaters of the room sealed type can be utilised in these locations.

INDEPENDENT GAS BOILERS

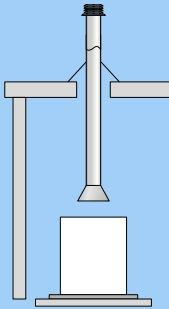

Open flued independent boilers should be connected to a double wall gas vent system which should preferably be located within the dwelling in order to reduce the risk of condensation. For external applications flue systems constructed from double wall insulated chimneys complying with BS EN 1856 should be used. Alternatively masonry chimneys lined with an approved chimney liner to BS EN 1856 or prefabricated chimney block systems may be used. In all cases the systems must be installed strictly in accordance with the manufacturers instructions such that they incorporate all the necessary firestop spacers and flashings.

BALANCED COMPARTMENT

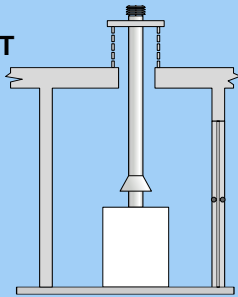

Where an independent boiler is sited in a separate single storey boiler house arrangement, a vertical balanced flue system can be incorporated. The installation should be carried out in accordance with the requirements of the manufacturer, the appropriate section of BS 5440 relating to "Balanced Compartment Installations" and in accordance with the requirements of the appropriate Building Regulations.

FAN ASSISTED FLUE ARRANGEMENTS

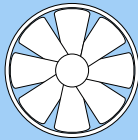

The use of electrically powered fans to augment natural chimney draught is a subject that must be discussed with both the fan and heating appliance manufacturers who will normally provide technical advice to ensure safe operation. It is important that in the event of the fan and/or power failure, the ignition process of gas appliances ceases immediately, a process normally achieved using specifically designated electrical wiring between the fan and the appliance.

COMBUSTION AIR REQUIREMENT

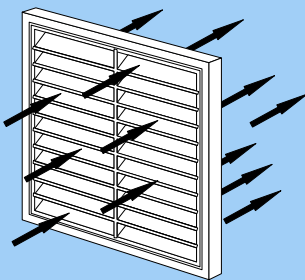

All gas burning appliances are required by law to have adequate provision for the supply of combustion air. The Regulations for open flued gas appliances having a rated input not exceeding 60kW dictate that a minimum uninterrupted ventilation area of 500 mm² must be provided to the room for each kW of rated input in excess of 7kW. Decorative fuel effect appliances normally require a minimum of 100 cm² of purpose provided ventilation to the room. In all cases the appliance manufacturers instructions must be consulted.

This is important as an inadequate supply of combustion air can create problems. Situations assumed to be "down draught" and spillage of fumes back into the room, which can be unpleasant and dangerous, are more frequently caused by insufficient provision of combustion air. Either the openings have not been provided, are not large enough or have been simply blocked off. If the appliance does not get all the air it needs to burn the fuel efficiently, incomplete combustion will occur resulting in the production of carbon monoxide and soot - yes - even when gas is burned.

Irrespective of the type of chimney system used, there are specific requirements for the type of terminal and its location.

Any chimney less than 175 mm in diameter must be fitted with an approved terminal. Those of 175 mm or greater in diameter do not require to be fitted with an approved terminal, but certain circumstances may justify the fitting of an appropriate terminal for either aesthetic reasons or the prevention of rainfall or debris entry. Individual appliance and/or chimney manufacturers should be consulted as appropriate.

The requirements for termination location and discharge are dictated by both Building Regulations and British Standards and require compliance with details shown in Figs 6, 7 and 8 on page 8.

CHIMNEY/FLUE TERMINATION

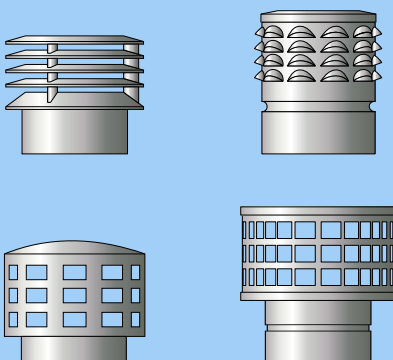

TYPES OF CHIMNEY AND FLUE SYSTEMS

The introduction of European Standard BS EN 1443: Chimneys - General Requirements, resulted in the categorising of chimneys and flues into three basic designations, defined as....

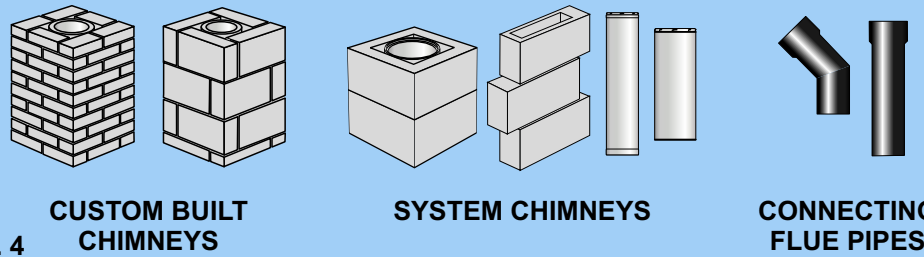

Fig. 4

DOUBLE WALL GAS VENT



STAINLESS STEEL LINED PREFABRICATED CHIMNEYS



CERAMIC OR CONCRETE LINED PREFABRICATED CHIMNEYS



MASONRY CHIMNEYS

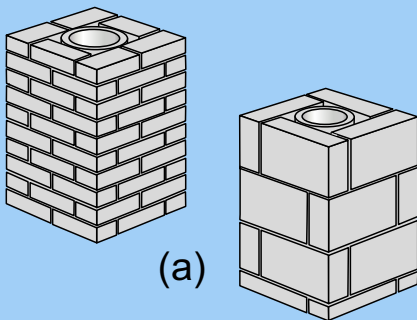

(a)

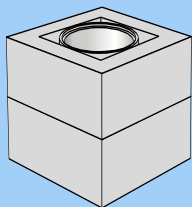

(b)

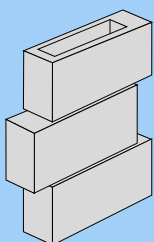

(c)

There are several basic chimney/flue systems that can be used with gas-fired appliances. A metal double wall flue system incorporating an air gap of between 6 mm and 20 mm and constructed with an aluminium or stainless steel liner and having an outer skin of aluminium/ zinc alloy coated steel or stainless steel for internal and external use. Where the flue pipe is only used internally a galvanised outer skin is permissible. Such products shall be certified to BS EN 1856 and are designated System Chimneys.

These chimney systems consist of two concentric stainless steel metal walls with insulation filling the annular space between them. These products can be used internally and externally. Such products must be certified to BS EN 1856 and are designated System Chimneys.

Similarly constructed as the previous category except that the inner liner is fabricated from either a refractory concrete or ceramic material. These products are likewise required to be certified to BS EN 1856 and are designated System Chimneys..

These can be divided into three categories:

a) Conventional brick or masonry construction with either clay/ceramic liners certified to BS EN 1457 or refractory concrete flue liners certified to BS EN 1857. The space around the liner is usually filled with a light weight insulating concrete. In some cases where used with a gas appliance it will be necessary to utilise a stainless steel flexible liner in addition to the constructed liner. It is not permitted to substitute a ceramic or concrete liner with a steel liner of any description. These are designated **Custom Built Chimneys**.

b) Prefabricated chimney block systems certified to BS EN 1858 comprise of an inner liner of concrete or clay/ceramic as specified above and an outer block of insulating concrete. Chimney blocks are designed to be used as a building unit and can normally accommodate a range of appliances, gas appliances included. In some cases they may also need to be lined with a flexible flue liner. The appliance manufacturer and chimney manufacturer should be consulted for guidance. These are designated **System Chimneys**.

c) Gas Flue Blocks certified to BS EN 1858 are designated **System Chimneys** and comprise of rectangular clay or concrete blocks with an integral narrow rectangular flue way. They are of the same modular size as a masonry building block and are usually designed so that they bond into adjacent brick or block work. Gas flue blocks, are often connected to a double wall gas vent in the roof space. The gas vent completes the chimney run through to the terminal. The blocks are usually built into the structure when the property is built and they should be carefully inspected for soundness or obstructions before being used. **It should be noted that gas fired appliances provided with a back boiler, must not be connected to Gas Flue Block systems unless a specific component is provided as part of the approved appliance for this purpose.**

Before using any existing chimney or re-fitting a gas appliance, it is vital to check that the chimney is safe, structurally sound and non-porous. Oversized, leaking or rough chimneys can be inefficient and dangerous. Blocked chimneys can kill!

LINING EXISTING CHIMNEYS

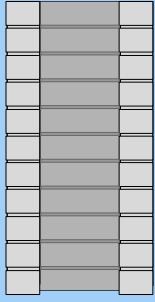

There are several types of chimney re-lining product suitable for use with gas appliances. It is most important that the chimney is swept and thoroughly cleaned before installing a liner so as to remove previous combustion deposits which may have the potential to damage the liner.

It should also be borne in mind that relining of any type does not strengthen a weak chimney, it only provides a repaired flue. If the chimney structure is mechanically weak, it should be examined by a structural engineer or builder and undergo appropriate repair other than relining.

Building Control approval is necessary for building new chimneys and in some cases for relining old chimneys, particularly if some alteration or a change of appliance occurs. It is best to consult the local authority for building regulation and planning requirements.

Flexible stainless steel liners are a convenient way to line an existing chimney which is to be used for a gas fired appliance. The liners must be manufactured, assessed and certified to BS EN 1856. When replacing an existing appliance connected to a chimney lined with a metallic liner, it is advisable to replace the liner if it is ten years old or more. Otherwise it should be thoroughly inspected throughout its length and replaced if necessary.

FLEXIBLE STAINLESS STEEL LINERS

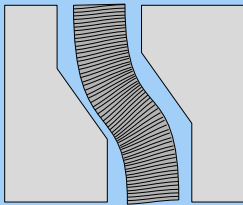

RIGID STAINLESS STEEL LINERS

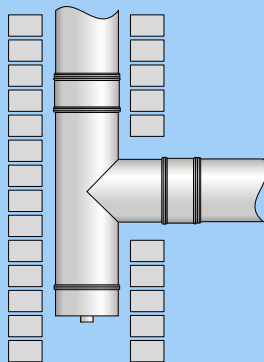

Rigid single wall stainless steel flue pipe certified to BS EN 1856 and made from 1 mm thick 316 or 304 grade stainless steel may be used to reline an existing chimney.

CLAY OR CONCRETE LINERS

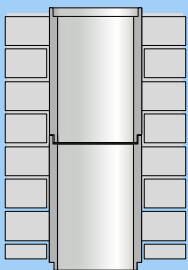

Clay liners certified to BS EN 1457 or concrete liners to BS EN 1857 may also be used for relining. Liners with spigot and socket joints must be fitted with the sockets facing upwards.

CONNECTING FLUE PIPES (SINGLE WALL)

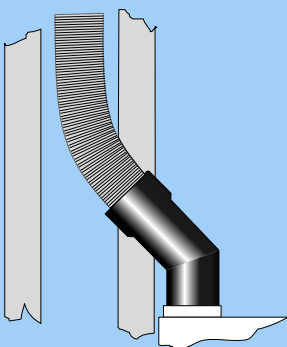

Single wall connecting flue pipes should only be used to connect a gas burning appliance to one of the types of chimney previously mentioned. They should not be used as a complete flue. Any flue pipe serving a gas appliance must be kept clear of any combustible materials including any materials likely to be located near the installation by the householder. The minimum air gap clearance that must be maintained is 25 mm (1"). Flue pipes may be constructed from stainless steel as described in BS EN 1856, or any flue pipe material described in the Building Regulations. All flue pipes must be applied such that any condensate is retained by the flue pipe system. Systems with spigot and socket joints must be fitted with the socket uppermost

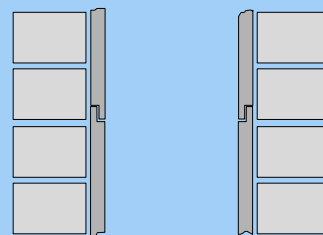
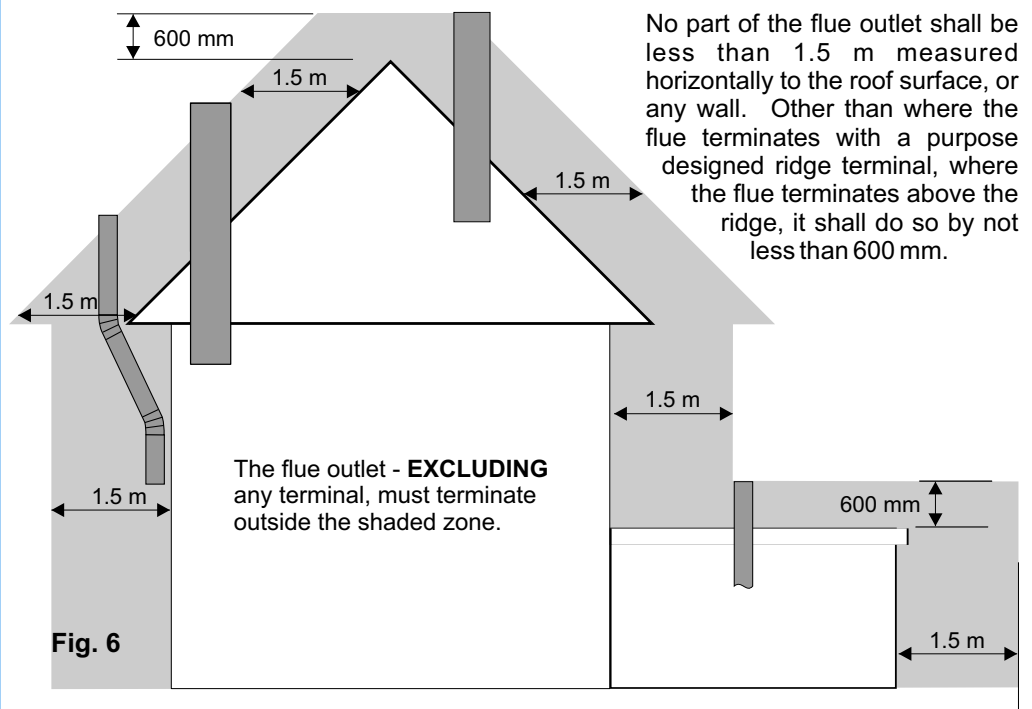

Fig. 5

FLUE TERMINATION POSITIONS FOR ANY CHIMNEY OR FLUE SYSTEM SERVING A NATURALLY VENTILATED GAS FIRED APPLIANCE

The illustrations on this page are representative of any type of internally or externally applied flue or chimney construction.

They have been drawn to depict the most likely type based on the location in or on the building.



ADDITIONAL REQUIREMENTS TO FIGURE 6 WHERE THE FLUE IS ADJACENT TO ANY WINDOW OR OPENING ON PITCHED OR FLAT ROOFS

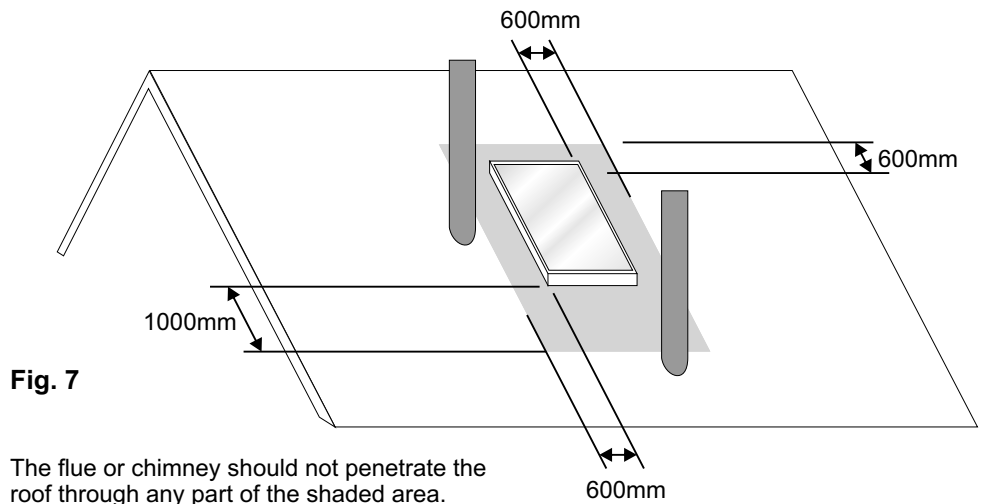

ADDITIONAL REQUIREMENTS TO FIGURE 6 WHERE THE FLUE TERMINATES AT A RIDGE VENT

Any edge of a Ridge Vent terminal must be 1.5m horizontally clear of any adjacent structure

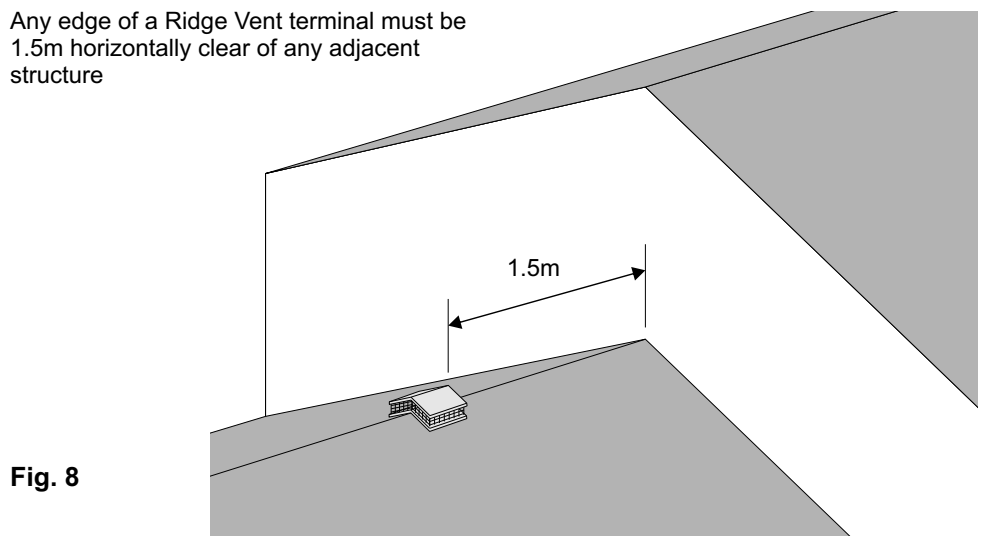

CHIMNEY, FLUE AND APPLIANCE ON SITE IDENTIFICATION (Notice Plate)

Where any of the chimney or flue products and/or a combustion appliance, (irrespective of fuel burned), is installed or renovated, it is a Mandatory Requirement that a Notice Plate is provided which identifies the appropriate equipment on site. It must be located in a convenient and accessible location, eg., near a services meter. Completion of the data required on the Notice Plate can be by the heating appliance installer, builder, chimney supplier/installer or other competent person. This is an example of the Notice Plate as defined in Building Regulation Approved Document J.

IMPORTANT SAFETY INFORMATION	
This label must not be removed or covered	
Property address	20 Main Street new Town
The hearth and chimney installed in the	Lounge
are suitable for	decorative fuel effect gas fire
Chimney liner	Double skin stainless steel flexible 200 diameter
Suitable for condensing appliance	no
Installed on	date
Other information (optional)	Designation of stainless steel liner stated by manufacturer to be T540 N2 S D 3
e.g. installers name, product trade names installation and maintenance advice, European chimney product designations, warnings on performance limitations of imitation elements e.g. false hearths	

Fig. 9

BUILDING REGULATIONS & STANDARD REFERENCES

Building Regulations appropriate to the UK are:-

England & Wales.

The Building Regulations Approved Document J

Scotland

Building Regulations Technical Standards Section 3

Northern Ireland

Building Regulations Northern Ireland Technical Booklet L

Copies of these Building Regulations can be obtained from the Stationery Office. Advice is also available from Local Authority Building Control Departments.

The installation of all flues must comply with the Clean Air Act, the Gas Safety Regulations and Local Authority Regulations.

OTHER USEFUL CONTACTS

CORGI

Council for Registered Gas Installers
1 Elmwood, Chineham Business Park,
Crockford Lane, Basingstoke,
Hampshire. RG24 8WG
Tel: 01785 811732

CORGI provide a list of Registered Gas Installers as well as information regarding the safe use of gas fired appliances.

NACS

National Association of Chimney Sweeps
Unit 15, Emerald Way,
Stone Business Park Stone,
Staffordshire ST15 0SR
Tel: 01785 811732

NACS provide a list of their members throughout the UK

NFA

National Fireplace Association
PO Box 583, High Wycombe. HP15 6XT
0845 643 1901

The NFA publish a series of guides on fireplaces and associated work including chimneys.

European and British Standards which relate to Flues and Chimneys

All of the standards referenced below are either directly applicable to chimneys and flues, or contain relevant content and are correct at the time of publication of this document.

As many of the standards relate to flue and chimneys for all fuels, for convenience and information, every relevant standard for all residential fuel types has been listed. Any Standards which are NOT pertinent to gas-fired appliances have been *italicised*.

BS EN 483:2000	Gas-fired central heating boilers. Type C boilers of nominal heat input not exceeding 70 kW. Replaced BS 5258: Pt 1; 1986
BS EN 509:2000	Decorative fuel-effect gas appliances. Replaced BS 5258: Pt 12; 1990.
BS 715: 2005	Specification for metal flue boxes for gas-fired appliances not exceeding 20kW.
BS 1251: 1987	Specification for open fireplace components.
BS EN 1443: 2003	Chimneys – general requirements
BS EN 1457: 1999	Chimneys, Clay/Ceramic flue liners. Requirements and test methods. Replaced BS 1181: 1989
BS EN 1806: 2006	Chimneys Clay/ceramic flue blocks for single wall chimneys. Requirements and test methods
BS EN 1856 - 1: 2003	Chimneys. Requirements for metal chimneys. System chimney products. Replaced BS 4543: Pts 2 and 3 & BS 715: 1993
BS EN 1856 - 2: 2004	Chimneys. Requirements for metal chimneys. Metal liners and connecting metal flue pipes Replaced BS 715: 1993
BS EN 1857: 2003	Chimneys - Components. Concrete flue liners. Replaced BS 7435: Pts 1-2
BS EN 1858: 2003	Chimneys, Components, Concrete flue blocks. Replaced BS 1289: Pt 1
BS EN 1859: 2000	Chimneys. Metal chimneys. Test methods. Replaced BS 4543: Pt 1:1990
BS 5871: 2005	Specification for installation of gas fires, convector heaters, fire/back boilers and decorative fuel effect gas appliances Pt 1: Gas fires, convector heaters and fire/back boilers. Pt 2: Inset live fuel effect gas fires of heat input not exceeding 15kW. Pt 3: Decorative fuel effect gas appliances of heat input not exceeding 15kW.
BS 5440: 2000	Installation of flues and ventilation for gas appliances of rated input not exceeding 70 kW. Pt 1 : 1990 Specification for installation of flues. Pt 2 : 1989 Specification for installation of ventilation for gas appliances.
<i>BS 6461-1:1984</i>	<i>Installation of chimneys and flues for domestic appliances burning solid fuel (including wood and peat). Code of practice for masonry chimneys and flue pipes</i>
BS 6999:1989	Specification for vitreous-enamelled low carbon steel flue pipes
BS 7977-1:2002	Specification for safety and rational use of energy of domestic gas appliances. Radiant/convectors Replaced BS 5258: Pts 5 and 16
BS 7977-2:2003	Specification for safety and rational use of energy of domestic gas appliances. Combined appliances. Gas fire/back boiler. Replaced BS 5258: Part 8
BS EN 12391-1: 2003	Chimneys. Execution Standard for metal chimneys. Chimneys for non-room-sealed appliances.
BS EN 12446 : 2003	Chimneys. Components. Concrete outer wall elements
BS EN 13063-1: 2005	Chimneys. System chimneys with clay/ceramic flue liners. Requirements and test methods for sootfire resistance
BS EN 13063-2: 2005	Chimneys. System chimneys with clay/ceramic flue liners. Requirements and test methods under wet conditions
BS EN 13069: 2005	Chimneys. Clay/ceramic outer walls for system chimneys. Requirements and test methods
BS EN 13216 : 2004	Chimneys. Test methods for system chimneys. Replaced BS 4543
BS EN 13502 : 2002	Chimneys. Requirements and test methods for clay/ceramic flue terminals. Replaced BS 1181:1999.

Copies of European and British Standards can be obtained from:

**British Standards Institution, 389 Chiswick High Road, Chiswick, London. W4 4AL.
Tel: 0208 9969000**

SOME DO'S AND DON'T'S

DO ...

DO ensure that when an appliance is fitted to an existing chimney system that it is inspected and tested for soundness and any defects are rectified.

DO ensure that chimney or flue system is always installed and supported and that all joints are properly, securely and efficiently made strictly in accordance with the manufacturers instructions.

DO ensure that the flue pipe connection from the appliance rises vertically for at least 600 mm (24") before any change of direction is contemplated. The reason for this is that the flue draught is crucial nearer the appliance because of the higher flue gas temperature. Any horizontal or angled runs at the bottom of the flue will create severe restriction to gas movement and affect appliance operation.

DO try to construct the chimney vertically all the way to the terminal that where bends are necessary, no part of the flue is installed at an angle more than 45° from the vertical.

DO ensure that the flue diameter is not less than the diameter of the appliance outlet.

DO ensure that the effective height of any chimney with bends (vertical distance between appliance and terminal) is at least twice the horizontal distance between the appliance and terminal.

DO try to position the chimney inside the building to avoid excessive cooling and risk of condensation.

DO ensure that the chimney is installed and located in accordance with Building Regulations and British Standards, particularly where distinct distances from combustible materials are required.

DO ensure that the chimney is thoroughly inspected, and that flue flow and smoke tests are carried out and that when the appliance is fitted there is no flue gas spillage.

DO remind the householder that a chimney and appliance must breathe which is why a permanent supply of combustion air must be provided and kept clear from obstruction.

DO advise the householder to have the gas appliance regularly and expertly serviced.

DO ensure that if a gas flue block or mixed system consisting of gas flue blocks and prefabricated gas vent is constructed that the gas flue block chimney is free of construction faults. Surplus mortar must be removed from the flue way to prevent blockage.

DO ensure that the flue is terminated in accordance with the Building Regulations and BS5440 Part 1. See Figures 6 to 8.

DO always consult your gas supplier or CORGI registered installer for advice if you are in any doubt.

DO ensure that the installation is carried out by a CORGI registered installer.

DON'T ...

DON'T use any single wall flue system as a chimney.

DON'T use uninsulated flue systems externally.

DON'T allow clothes, furnishings or any combustible materials to come into contact with the surface of any flue pipe or prefabricated metal chimney.

DON'T connect the gas appliance until the installation has been checked and approved by a gas engineer registered with CORGI

DON'T use bends if they can be avoided.

DON'T run horizontal flue anywhere in the system.

DON'T position the chimney externally if it can be avoided.

DON'T be tempted to use non BS EN certificated flue and chimney systems; they may only last for a short time and will have to be replaced by the correct product. It will then be at least twice as expensive in the long run.

